

DIGITAL PIANO USER MANUAL

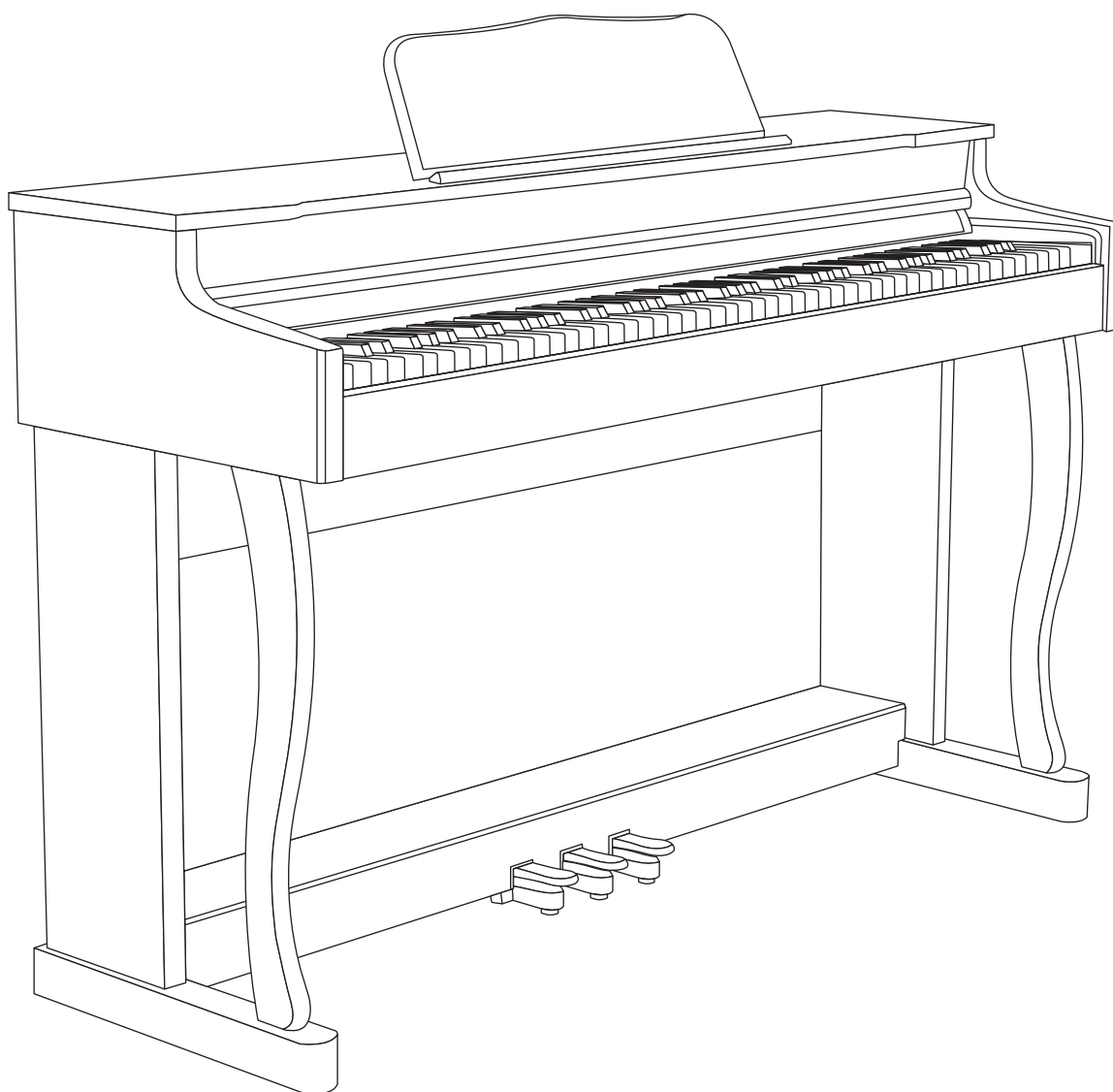

This product is subject to change without prior notice



FUNCTION INTRODUCTION

Thank you for choosing our digital piano. This product is elegant and exquisite. It is the perfect presentation of contemporary new electronic technology and acoustics.

- Before using the instrument, you must read this manual carefully.



DIGITAL SOUND SOURCE BASED ON DSP

Its core uses DSP new digital sound source, digital audio analog sampling, for your performance to bring realistic hearing experience.

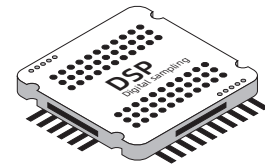

88 PROGRESSIVE HEAVY HAMMER KEYS

88 key progressive lever heavy hammer keyboard gives you a real touch like playing on a grand piano.

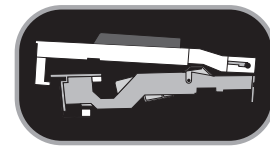

- Item No.: CDP-808
- Keyboard: 88 standard heavy hammer keyboard
- Color: black and white wood grain
- Keyboard: 88 standard heavy hammer keyboard
- France dream dream sound source
- Tone: electric piano tone
- Power switch/master volume control
- Soft pedal / Sostenuto pedal / sustain pedal
- MIDI function / audio output / audio input
- Dual headphone audio output
- USB interface link: cell phone, tablet, computer

REMARK !

- This product is an electro-acoustic instrument product. It is normal that there is a little current sound in the speaker or earphone after power-on.
Keep away from "radio, TV, antenna receiver, router, refrigerator, TV, motor and other RF electrical interference sources" during use.



Installation Guide

Attention !

- This product needs to be installed by adults, do not allow minors to install independently!

Assembled brackets

- Immediately after opening the package, please check that it contains all items. If anything is missing, please contact your distributor.

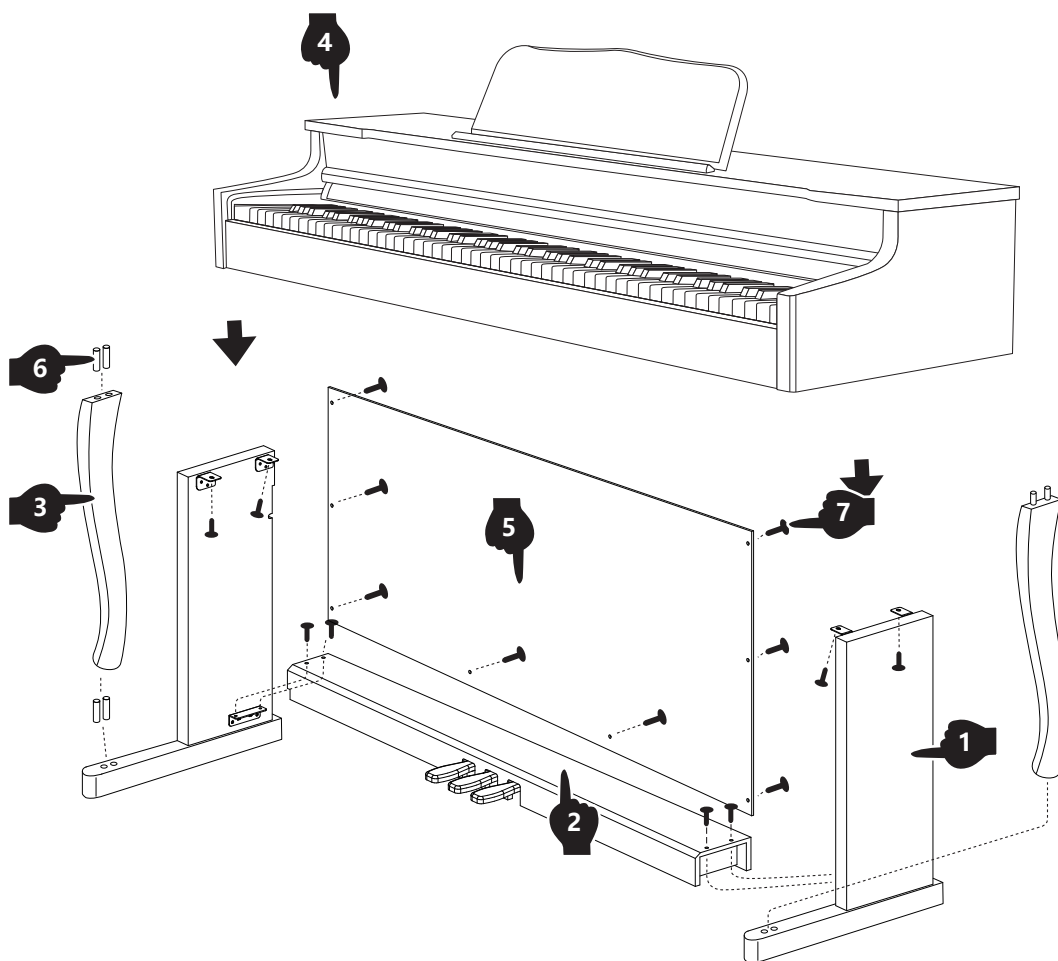

- ① Left/right support plate
- ② Footrest crossbeam
- ③ Left/right support column
- ④ Piano case
- ⑤ Back fixing plate
- ⑥ Round wood pegs (8 PCS)
- ⑦ Screws (16 PCS)



Illustration of the socket

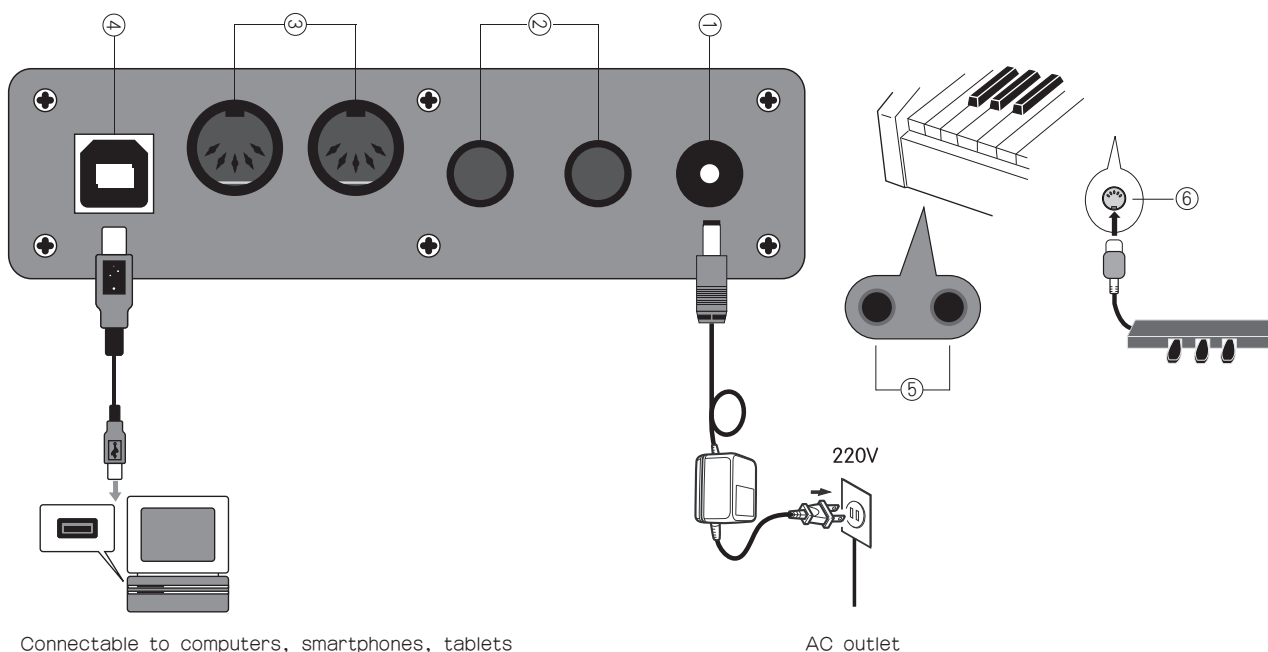

Connectable to computers, smartphones, tablets

AC outlet

1 POWER LINE CONNECTION

1. When used according to the access power line, one end is inserted into the socket at the bottom of the piano operation plate. The other end is inserted into the 220V household power socket (Figure 1)
2. If you do not use this product for a long time, unplug the power cord and keep it properly.

2 AUDIO INPUT / OUTPUT PLUG

1. The audio output socket can be connected to large sound box equipment.(Figure 2)
2. The audio input socket connects the external sound source to the electric piano for playback. (Figure 2)

3 MIDI INPUT AND OUTPUT SOCKET

The MIDI interface of this digital piano can be connected to music equipment withMIDI.(Figure 3)

4 USB TRANSPORT INTERFACE

Using the USB transmission interface to connect with the computer Through the computer installed Music software, to learn or play the keyboard to play, composition, storage and other functional operations. Edited music and built-in accompaniment to music software.It can be played by software connected to the digital piano or played by accompaniment music (Figure 4)

5 DOUBLE HEADSET SOCKET

Connecting the headset will automatically cut off the output of the built-in loudspeaker,so it won't disturb others when playing .This product has two headphone sockets,which can insert two headphones at the same time. (Figure 5)

6 PEDAL SOCKET

Insert the end of the pedal line into the circular socket of the bottom of the piano, and you can connect the 3 pedal sound effects .In turn : weak tone, posterior extension and portamento (Figure 6)



Pedal unit function

The optional pedal unit is equipped with 3 foot pedals that produce a variety of intense effects similar to those of acoustic piano pedals.

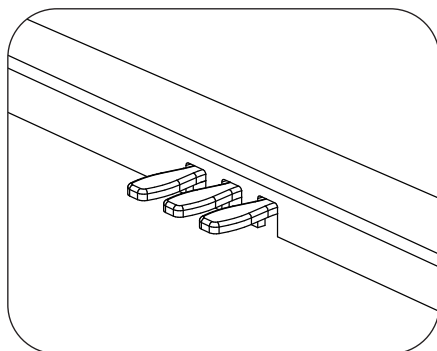

1 Sustain (right) pedal

The damper pedal functions in the same way as the damper pedal on an acoustic piano. When the damper pedal is depressed, the note will be extended. Releasing the pedal immediately stops the sustain.

The "half-pedal" effect helps you create a half sustain effect with the damper pedal, depending on how far you depress the pedal.

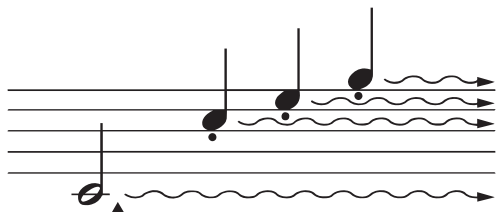

➡ If you depress the damper pedal here, the note played before releasing the pedal note will be extended for a longer period of time.

2 sustain (middle) pedal

If you play a note or chord on the keyboard and press the sustain pedal, as long as the pedal is pressed (just like a damper pedal) those notes will be extended, but the notes played after them will not be extended. This extends the chord note, while the other notes are "broken".

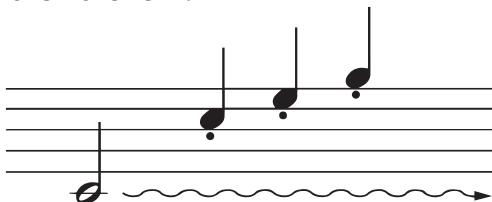

➡ If you press and hold this note and depress the sustain pedal, you can sustain the note until the pedal is released. until the pedal is released.

3 Soft Tone (Left) Pedal

Depressing the soft pedal reduces the volume and slightly changes the tone of the note being played at that moment. Depressing the soft pedal will not affect the notes already played.



Function Operation

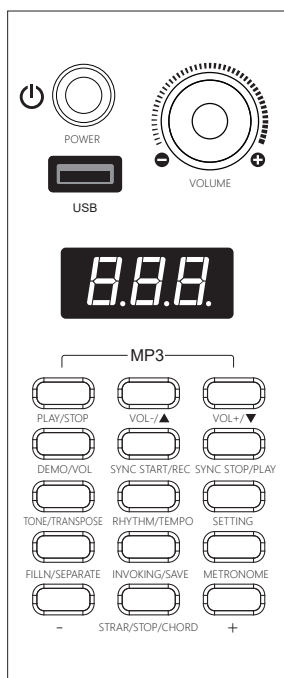

1 Master Volume Control

- Use the (Volume) knob to control the master volume level.
- (Volume) knob to the right to turn the master volume increases , The master volume is reduced by turning the (volume) knob to the left.
- Before turning on the power, turn the (volume) knob to the left to turn the master volume to the minimum.
- To turn off the digital piano, first turn the (volume) knob to the left to turn the master volume to minimum.



2 Start/Stop

- This mode is automatically exited in the Playback, Demonstration, Metronome, etc. modes.
- First short press of the (STRAR/STOP/CHORD) key starts the rhythm
- Second short press of the (STRAR/STOP/CHORD) key stops the rhythm

LCD display :

SET
Main A

Button:



STRAR/STOP/CHORD

3 Metronome

This digital piano has a built-in common metronome for reference when practicing or playing.

- The first time you press the (metronome) key to turn on the metronome, the "da, da, da" sound appears, press the (+) key or (-) key to speed up or slow down the tempo, range: 1/4, 2/4, 3/4, 4/4
- Press the (Metronome) key a second time briefly to turn off the metronome.

LCD display :

SET
ON
Metro

Button:

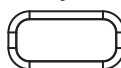

METRONOME



+



-

4 CHORDS

- Short press (Rhythm/Tempo) key - Press (+) or (-) key to select the desired rhythm - Short press (Start Stop/Chord) key to start the rhythm Rhythm 1, long press (Start Stop, Chord) to start the chord function.

Note: The corresponding chord accompaniment is played when the multi-fingerings are pressed in the range of keys A1-F4#.

LCD display :

SET
ON
Chord

Button:

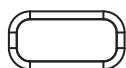

RHYTHM/TEMPO

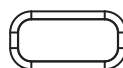

+



-



STRAR/STOP/CHORD

5 Synchronous start and synchronous stop

- Short press the (Sync Start/Record) key to turn on the Sync Start function.
- Short press the (Sync Stop/Record) key to turn off the sync function.
- When playing a chord, press the (Sync Start/Record) key briefly for the first time - press a key in the A1-F4# range of the chord area to enter sync mode.
- For chord synchronization, please refer to the instructions for single-finger accompaniment or multi-finger accompaniment.

LCD display :

SET
OFF
SynStart

Button:



SYNC START/REC

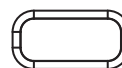

SYNC STOP/PLAY



Function Operation

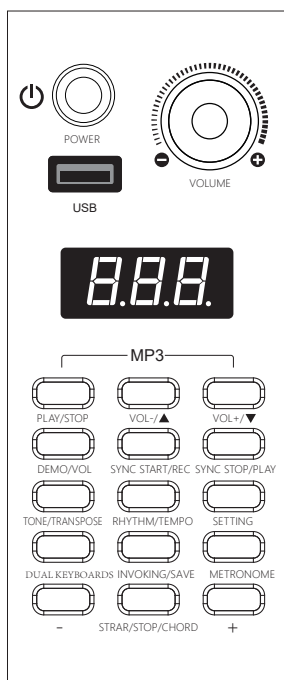

6 Dual keyboards

- With the rhythm started, short press the (Dual keyboards) key to turn on the insert function.
- The insertion function can only be activated with the insertion and release rhythm.
- Short press the (Dual keyboards) key to toggle between A/B paragraphs.

LCD display : Button:

7 DEMO/VOL

- When starting the rhythm or demonstration song function - Press and hold the (DEMO/VOL) key to turn on the volume function - Press the (+) key or (l) key to adjust the volume.
- The volume is adjusted when the current state is Demo, and the other states are Rhythm volume. Range 000-100 Default 80.

LCD display : Button:

8 RHYTHM/TEMPO

- Press and hold the (RHYTHM/TEMPO) key to switch to the beat type selection, use the (+) key or (-) key to select the beat type, 1/4,2/4,3/4,4/4.

LCD display : Button:

9 TRANSPOSE

- Press and hold the (TONE/TRANSPOSE) key to switch to transpose adjustment, and use the (+) key or (-) key to select the appropriate scale.
- Press the (+) key to increase upwards.
- Press the (-) key to decrease downward.
- Press the (+) and (-) keys simultaneously to shift back to the preset value.
- Shift -12 to 12 Default value is 0.

LCD display : Button:

10 DEMO

- This digital piano has 120 built-in demos to showcase a wide range of tones. Users can get a first glimpse of this digital piano through the demonstration songs.
 - Short press (DEMO/VOL) to select the desired track with the (+) or (-) key - Short press (STRAR/STOP/CHORD) to start or or stop playing the demo song.
- Short press (SETTING) to select the practice function while playing a demonstration song to enable the left hand/right hand/left and right hand practice functions.

LCD display : Button:



Function Operation

11 DUAL KEYBOARD (DETACHED)

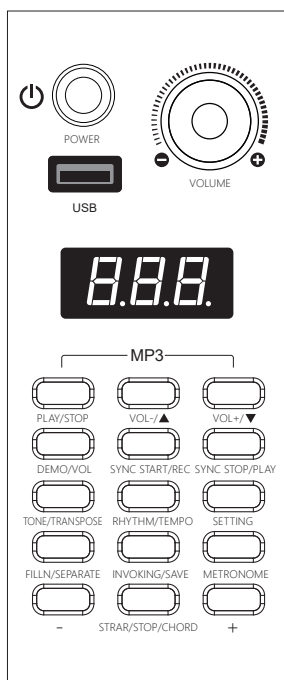

- In the keyboard separation method, the keyboard is divided into two parts with the keyboard separation point, the left hand part is played with a regular tone and the right hand part is played with a different tone.
- Long press (FILLN/SEPARATE) key to open the dual keyboard function - short press (SETTING) key to select the keyboard separation point function, use (+) key or (-) key or directly press the piano key to select the separation point.
- Short press (SETTING) key to enter the setting status, select the left keyboard volume function, you can adjust the left key keyboard volume.
- The first long press of the (FILLN/SEPARATE) key turns on the keyboard separation (dual keyboard) function, and the second long press of the (FILLN/SEPARATE) key turns off the keyboard separation (dual keyboard) function.

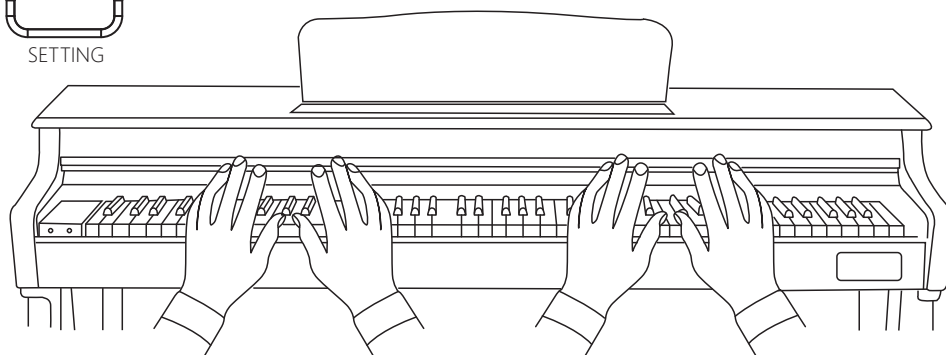
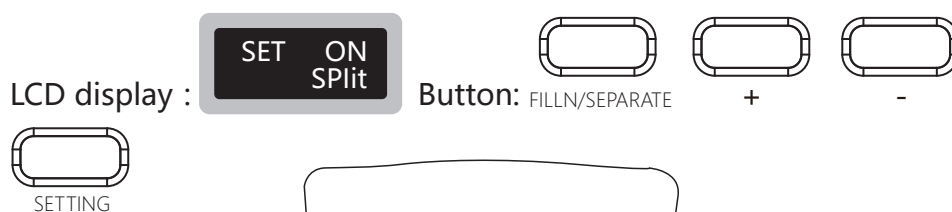

12 Recording and playback (playback)

- Press and hold the (SYNC START/REC) key to enter the recording ready state, press any key or short press the (STRAR/STOP/CHORD) key to start recording.
- If the chords are open, the recording includes both the rhythm and the melody, otherwise only the melody is recorded.
- Long press (SYNC START/REC) key or short press (STRAR/STOP/CHORD) key to end recording.
- Press and hold the (SYNC STOP/PLAY) button to play the previously recorded music.



13 STRENGTH

- Long press (SETTING) button to toggle the intensity adjustment.
- This digital piano has multi-level strength touch.
- The power-on default is strength on.





Function Operation

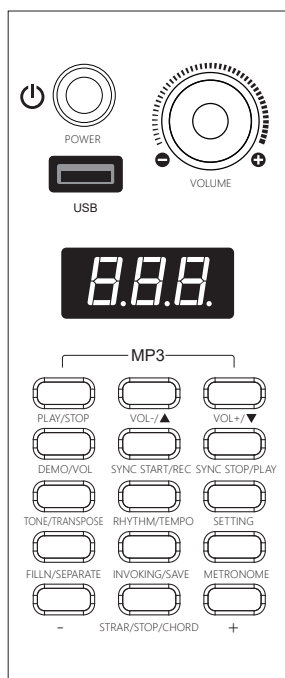

14 TEMPO

- Long press the (RHYTHM/TEMPO) key to switch to the speed adjustment status, use the (+) key or (-) key to adjust knot. You can adjust the tempo of the rhythm, demonstration song, metronome, and recording.
- Press the (+) and (-) keys simultaneously to quickly restore the default tempo of the current tempo or demonstration tune.
- Different speed 30-300 Preset 120.



LCD display :

Button: RHYTHM/TEMPO

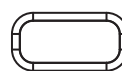

15 INVOKING/SAVE

- A long press on the (INVOKING/SAVE) key saves the current state of the instrument, including all parameters such as tone, rhythm type, rhythm volume, tempo, transpose, intensity type, etc., which can be recalled by a short press on the (INVOKING/SAVE) key to quickly return the instrument to that state when used again.
- Short press the (INVOKING/SAVE) key to recall the function.



LCD display :

Button:

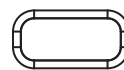
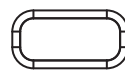
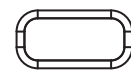

16 MP3

- Short press (VOL- /▲) to switch to the previous song, long press to reduce the MP3 volume.
- Short press (VOL+/▼) to switch to the next song, long press to increase MP3 volume.
- Press the (PLAY/STOP) key briefly to play the song from the MP3.
- Press and hold the (PLAY/STOP) key to stop playing the song in the MP3.

Button:

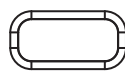

PLAY/STOP



VOL- /▲

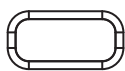

VOL+/▼

17 SETTING

Note: Short press the (SETTING) key to select dual tone, reverb, chorus, harmony, and tuning functions, and adjust them with the (+) key or (-) key. Reverb (1-8), Chorus (1-8), Chorus (1-10), Tuning (-100 to 100)

Button:



SETTING



+

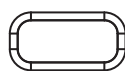

-



Appendix

Tone Name	Tone Name	Tone Name	Tone Name	Tone Name
000 Acoustic Grand Piano	062 Synth Brass 1	124 Seashore	186 Echo Bell	248 Jetplane
001 Bright Acoustic Piano	063 Synth Brass 2	125 Bird Tweet	187 Echo Pan	249 Starship
002 Electric Grand Piano	064 Soprano Sax	126 Telephone Ring	188 Bian Zhong	250 Scratch
003 Honky-tonk Piano	065 Alto Sax	127 Helicopter	189 Yang Qin 2	251 Wind Chime
004 Electric Piano1	066 Tenor Sax	128 Applause	190 Recorder 2	252 Bi Li
005 Electric Piano2	067 Baritone Sax	129 Gunshot	191 Pan Flute 2	253 JUNO Strings
006 Harpsichord	068 Oboe	130 Piano w	192 Trumpet 2	254 Funk Gt 1
007 Clavichord	069 English Horn	131 Piano d	193 Trombone 2	255 Funk Gt 2
008 Celesta	070 Bassoon	132 Bandoneon	194 Trombone 3	256 Tubular-bell 2
009 Glockenspiel	071 Clarinet	133 Er Hu	195 Pai Gu	257 Tubular-bell 3
010 Music box	072 Piccolo	134 Gu Zheng	196 Qin	258 Detuned EP1
011 Vibraphone	073 Flute	135 Ukulele	197 Contrabass 2	259 E.Piano 1v
012 Marimba	074 Recorder	136 Organ 1	198 Harp 2	260 Creaking
013 Xylophone	075 Pan Flute	137 Organ 2	199 Celesta 2	261 Door
014 Tubular Bells	076 Bottle Blow	138 Harmonica 2	200 Glockenspiel2	262 Dist. Gt 2
015 Dulcimer	077 Shakuhachi	139 Clean Gt 2	201 Music Box 2	263 Dist. Gt 3
016 Hammond Organ	078 Whistle	140 Clean Gt 3	202 Upright Piano 2	264 Tuba 2
017 Percussive Organ	079 Ocarina	141 Liu Qin	203 Upright Piano 3	265 MuteTrumpet 2
018 Rock Organ	080 Lead 1 (square)	142 Pi Pa	204 Vibraphone 2	266 Screaming
019 Church Organ	081 Lead 2 (sawtooth)	143 Sitar 2	205 Hu Lu Si	267 Punch
020 Reed Organ	082 Lead 3 (calliope lead)	144 Mellow Gt	206 Marimba 2	268 French Horn 2
021 Accordion	083 Lead 4 (chiff lead)	145 Chorus Gt	207 Di Zi 1	269 French Horn 3
022 Harmonica	084 Lead 5 (charang)	146 Reed Organ 2	208 Di Zi 2	270 Dog
023 Tango Accordion	085 Lead 6 (voice)	147 60's Organ	209 Xylophone 2	271 HorseGallop
024 Acoustic Guitar (nylon)	086 Lead 7 (fifths)	148 Synth 1	210 Nylon Gt 2	272 Bird 2
025 Acoustic Guitar (steel)	087 Lead 8 (bass+lead)	149 Synth 2	211 Nylon Gt 3	273 Telephone 2
026 Electric Guitar (jazz)	088 Pad 1 (new age)	150 Synth 3	212 Analog Brs1	274 Zhong Hu
027 Electric Guitar (clean)	089 Pad 2 (warm)	151 Synth 4	213 Analog Brs2	275 Ma Tou Qin
028 Electric Guitar (muted)	090 Pad 3 (polysynth)	152 Zhong Ruan	214 Heart Beat	276 Luo 1
029 Overdriven Guitar	091 Pad 4 (choir)	153 Da Ruan	215 Footsteps	277 Luo 2
030 Distortion Guitar	092 Pad 5 (bowed)	154 Mandolin	216 Accordion 2	278 Castanets
031 Guitar Harmonics	093 Pad 6 (metallic)	155 Mandolin 2	217 Accordion 3	279 Concert BD
032 Acoustic Bas	094 Pad 7 (halo)	156 Yue Qin	218 Siren	280 Machine Gun
033 Electric Bass (finger)	095 Pad 8 (sweep)	157 San Xian	219 Train	281 Laser gun
034 Electric Bass (pick)	096 FX 1 (rain)	158 Bottle Blow 2	220 Ba Wu	282 Explosion
035 Fretless Bass	097 FX 2 (soundtrack)	159 Shakuhachi 2	221 Muted Gt 2	283 Feedback Gt
036 Slap Bass 1	098 FX 3 (crystal)	160 Violin 2	222 Muted Gt 3	284 Gt.Feedback
037 Slap Bass 2	099 FX 4 (atmosphere)	161 Viola 2	223 Rain	285 Organ 101
038 Synth Bass 1	100 FX 5 (brightness)	162 Cello 2	224 Thunder	286 Detuned Or1
039 Synth Bass 2	101 FX 6 (goblins)	163 Harpsichord 2	225 Wind	287 60s E.Piano
040 Violin	102 FX 7 (echoes)	164 Gu Qin	226 Stream	288 E.Piano 3
041 Viola	103 FX 8 (sci-fi)	165 Hawaiian Gt	227 Bubble	289 Melodic Tom 2
042 Cello	104 Sitar	166 Choir Aahs2	228 Soprano Sax 2	290 808 Tom
043 Contrabass	105 Banjo	167 Voice doo 2	229 Soprano Sax 3	291 Electric Percussion
044 Tremolo Strings	106 Shamisen	168 Synth Voice2	230 Alto Sax 2	292 Santur 3
045 Pizzicato Strings	107 Koto	169 Rock Organ 2	231 Strings	293 Pai Xiao
046 Orchestral Harp	108 Kalimba	170 Church Organ 2	232 Guan Zi 1	294 South Xiao
047 Timpani	109 Bagpipe	171 Shen 1	233 Guan Zi 2	295 Xiao
048 String Ensemble 1	110 Fiddle	172 Shen 2	234 Oboe 2	296 Kou Di
049 String Ensemble 2	111 Shanai	173 Brass 2	235 EnglishHorn 2	297 Xun
050 Synth Strings 1	112 Tinkle Bell	174 Synth Brass 3	236 Bassoon 2	298 Gao Hu
051 Synth Strings 2	113 Agogo	175 Square 2	237 Clarinet 2	299 Gt.CutNoise
052 Choir Aahs	114 Steel Drums	176 Sine Wave	238 Tenor Sax 2	300 String Slap
053 Voice Oohs	115 Woodblock	177 Saw 2	239 Tenor Sax 3	301 Fl.KeyClick
054 Synth Voice	116 Taiko Drum	178 Doctor Solo	240 BaritoneSax 2	302 Car-Engine
055 Orchestra Hit	117 Melodic Tom	179 Vox Lead	241 HonkyTonk w	303 Car-Stop
056 Trumpet	118 Synth Drum	180 Piccolo 2	242 Rhodes2	304 Car-Pass
057 Trombone	119 Reverse Cymbal	181 Flute 2	243 Steel Gt 2	305 Car-Crash
058 Tuba	120 Guitar Fret Noise	182 Space Voice	244 Steel Gt 3	306 Organ 201
059 Muted Trumpet	121 Breath Noise	183 Syn Mallet	245 12-str.Gt	307 Detuned Or2
060 French Horn	122 Seashore	184 Brightness 2	246 Burst Noise	308 Na Zi 1
061 Brass Section	123 Bird Tweet	185 Goblin 2	247 Laughing	309 Na Zi 2



Appendix I

Tone	Name	Tone	Name	Tone	Name	Tone	Name	Tone	Name
310	Ban Hu	372	EnglishHorn 3	434	Marimba 2	496	60s E.Piano 2	558	Bian Zhong 3
311	Jing Hu	373	Bassoon 3	435	Xylophone 2	497	Chorus Gt 2	559	Screaming3
312	Hu Ensemble 1	374	Fretless Bass	436	Honky-tonk Piano 2	498	Rain 3	560	Punch3
313	Hu Ensemble 2	375	Fretless Bass 2	437	Hu Lu Si 2	499	Thunder 2	561	Heart Beat3
314	Detuned EP2	376	Fretless Bass 3	438	Pai Xiao 2	500	Wind 2	562	Footsteps3
315	E.Piano 2v	377	Mandolin 3	439	South Xiao 2	501	Stream 2	563	Brightness 3
316	Acoustic Bass	378	Hammond Organ 2	440	Square 3	502	Siren 2	564	Goblin 2
317	Acoustic Bass2	379	Hammond Organ 3	441	Sine Wave 2	503	Funk Gt 3	565	Echo Bell2
318	Acoustic Bass3	380	Reed Organ 3	442	Cello 3	504	Piano w 2	566	Echo Pan2
319	Electric Guitar2 (jazz)	381	Ukulele 2	443	Brass 3	505	Bright Acoustic Piano 3	567	Gt.CutNoise3
320	Electric Guitar3 (jazz)	382	Organ 3	444	Shakuhachi 3	506	Whistle 3	568	String Slap3
321	Grand Piano K 2	383	Rock Organ 3	445	Explosion 2	507	Ocarina 3	569	Bi Li 3
322	Dream Piano	384	Glockenspiel3	446	Clavichord 3	508	Banjo 3	570	Ba Wu 3
323	Harmonica 3	385	Clavichord 2	447	Ba Wu	509	Synth Drum 3	571	Ban Hu 3
324	Piccolo 3	386	Tinkle Bell 2	448	Di Zi 3	510	Reverse Cymbal 3	572	Jing Hu 3
325	Flute 3	387	Agogo 2	449	Oboe 3	511	Applause 3	573	Synth 1
326	Ocarina2	388	Shakuhachi 2	450	English Horn 3	512	Gunshot 3	574	Synth 2
327	Shamisen2	389	Whistle 2	451	Bassoon 3	513	Detuned Or3	575	Bandoneon 3
328	Koto2	390	Synth Bass 3	452	Bird Tweet 3	514	Santur 2	576	Guitar Fret Noise3
329	Celesta 3	391	Strings3	453	Telephone Ring 3	515	Mandolin 3	577	Breath Noise3
330	Shen 3	392	Acoustic Grand Piano 2	454	Helicopter2	516	Doctor Solo 2	578	Seashore 3
331	Xiao2	393	Bright Acoustic Piano 2	455	Bi Li	517	Vox Lead 2	579	Shamisen 3
332	Sitar 3	394	Tango Accordion 2	456	Guan Zi 1	518	Space Voice 2	580	Koto 3
333	Alto Sax 2	395	Distortion Guitar 2	457	Guan Zi 2	519	Syn Mallet 2	581	Kalimba 3
334	Tenor Sax 3	396	Guitar Harmonics 2	458	Dog 2	520	808 Tom 3	582	Bagpipe 3
335	Kalimba 2	397	Steel Drums 2	459	HorseGallop 2	521	Electric Percussion 3	583	Fiddle 3
336	Bagpipe 2	398	Woodblock 2	460	Pai Gu 2	522	Jetplane 33	584	Shanai 3
337	Bandoneon 2	399	Taiko Drum 2	461	Qin 2	523	Starship 3	585	Rain
338	Recorder 3	400	Ban Hu 2	462	Bian Zhong 2	524	Concert BD 2	586	SoundTrack
339	Pan Flute 3	401	Jing Hu 2	463	Jetplane 2	525	Sine Wave 3	587	Crystal
340	Music Box 3	402	Breath Noise 2	464	Starship 2	526	Bassoon	588	Atmosphere
341	Banjo 2	403	Seashore 2	465	Burst Noise 2	527	Clarinet	589	Brightness
342	Clarinet 3	404	Zhong Hu 2	466	Alto Sax 3	528	Tenor Oboe	590	Vibraphone
343	Electric Bass (pick)	405	Ma Tou Qin 2	467	MuteTrumpet 3	529	Mellow Gt 2	591	Goblins
344	Electric Bass2 (pick)	406	Vibraphone 3	468	Punch	530	Hawaiian Gt 2	592	Echoes
345	Santur	407	Marimba 3	469	Heart Beat 2	531	Ukulele 3	593	Sci-Fi
346	Percussive Organ2	408	Xylophone 3	470	Footsteps 2	532	Castanets 3	594	CalliopeLead
347	Percussive Organ3	409	Applause 2	471	HonkyTonk w 3	533	Fl.KeyClick	595	Chiff Lead
348	Acoustic Bas 2	410	Gunshot 2	472	Rhodes3	534	Liverpool Bass	596	Charang Lead
349	Electric Bass2 (finger)	411	Melodic Tom 2	473	Saw 3	535	Picked Bass	597	Voic Lead
350	Electric Bass 2(pick)	412	Synth Drum 2	474	Liu Qin 2	536	Prog Rock Bass	598	5th Lead
351	Fretless Bass2	413	Synth Voice 3	475	Pi Pa 2	537	fretless bass	599	Bass Lead
352	Glockenspiel 2	414	Orchestra Hit 2	476	Zhong Ruan 2	538	Wooden case bass	600	Funk Gt 1
353	Fiddle 2	415	Hu Ensemble 3	477	Da Ruan 2	539	Electric Guitar 3(clean)	601	Funk Gt 2
354	Shanai 2	416	Tremolo Strings 2	478	Car-Engine 2	540	Overdriven Guitar 3	602	Warm Piano
355	Guitar Fret Noise2	417	Pizzicato Strings 2	479	Car-Stop 2	541	Chorus Gt 3	603	Chorused Piano
356	Percussive Organ	418	Electric Guitar 2(clean)	480	Car-Pass 2	542	Timpani 3	604	70s E organ
357	Muted Trumpet 2	419	Overdriven Guitar 2	481	Car-Crash 2	543	Pizzicato Strings	605	France Accordion
358	French Horn2	420	Orchestral Harp 3	482	Yue Qin 2	544	Tremolo Strings	606	Spanish Guitar
359	Trumpet 3	421	Gao Hu 2	483	San Xian 2	545	Orchestral Harp	607	Rubber Bass
360	Tuba 3	422	Er Hu 2	484	Gt.CutNoise 2	546	Orchestra Hit	608	Slow Violin
361	Machine Gun 2	423	Timpani 2	485	String Slap 2	547	Shakuhachi 3	609	Analog Strings
362	Laser gun 2	424	Reverse Cymbal 2	486	Fl.KeyClick 2	548	New Age	610	Grow Sax
363	Train 2	425	Choir Aahs 2	487	BaritoneSax 3	549	Warm Pad	611	Bass Clarinet
364	Castanets 2	426	Voice Oohs 2	488	Laughing 2	550	PolySynth		
365	Bottle Blow 3	427	12-str.Gt 2	489	Screaming 2	551	ChoirPad		
366	Choir Aahs3	428	Brass Section 2	490	Recorder 2	552	BowGlass		
367	Voice doo 3	429	Kou Di 2	491	Pan Flute 2	553	Metal Pad		
368	Gu Qin 2	430	Xun 2	492	Scratch 2	554	Halo Pad		
369	Gu Zheng 2	431	Melodic Tom 3	493	Wind Chime 2	555	Sweep		
370	Bass Drum	432	808 Tom 2	494	Creaking 2	556	Pai Gu 3		
371	Bubble 2	433	Electric Percussion 2	495	Door 2	557	Qin 3		



Appendix II

Rhythm	LCD	Rhythm	LCD	Rhythm	LCD	Rhythm	LCD
001	6.8BLUES	062	COUNTRY7	123	FUNK3	184	PunkRock5
002	4.4BLUES	063	COUNTRY8	124	FUNK4	185	JIVEROCK
003	5.4BEAT1	064	COUNTRY9	125	FUNK5	186	ROCKSHUFFLE
004	5.4BEAT2	065	COUNTRY10	126	FUNK6	187	ROCK'N'ROLL1
005	BOOGIEWOOGIE	066	COUNTRY11	127	FUNK7	188	ROCK'N'ROLL2
006	soulshuffle	067	COUNTRY12	128	R&B1	189	BEGUINE1
007	RAGTIME1	068	COUNTRY13	129	R&B2	190	BEGUINE2
008	RAGTIME2	069	COUNTRY14	130	R&B3	191	CARIBBEAN
009	SHUFFLE1	070	COUNTRY15	131	R&B4	192	BOLERO
010	SHUFFLE2	071	COUNTRY16	132	R&B5	193	DANGDUT
011	SHUFFLE3	072	COUNTRYPOP	133	R&B6	194	CHINA
012	SHUFFLE4	073	COUNTRYSHUFFLE1	134	16BEAT1	195	JIANGNAN
013	BLUES1	074	COUNTRYSHUFFLE2	135	16BEAT2	196	XIZANG
014	BLUES2	075	COUNTRYSWING	136	16BEAT3	197	YUNNAN
015	BLUES3	076	LATIN1	137	16BEAT4	198	HAWAII
016	BLUES4	077	LATIN2	138	16BEAT5	199	GUARACHA
017	TWIST1	078	LATIN3	139	16BEAT6	200	CHARLESTON
018	TWIST2	079	LATIN4	140	16BEAT7	201	V6.8BLUES
019	TWIST3	080	LATIN5	141	16BEAT8	202	V4.4BLUES
020	TWIST4	081	LATIN6	142	POP1	203	V5.4BEAT1
021	GOSPEL1	082	TANGO1	143	POP2	204	V5.4BEAT2
022	GOSPEL2	083	TANGO2	144	POP3	205	VBOOGIEWOOGIE
023	GOSPEL3	084	RUMBA1	145	POP4	206	Vsoulshuffle
024	R&B	085	RUMBA2	146	POP5	207	VRAGTIME1
025	SWING1	086	RUMBA3	147	POP6	208	VRAGTIME2
026	SWING2	087	CHACHA1	148	POP7	209	VSHUFFLE1
027	BLUEBOOGIE	088	CHACHA2	149	POP8	210	VSHUFFLE2
028	JAZZ1	089	CHACHA3	150	VINTAGE1	211	VSHUFFLE3
029	JAZZ2	090	CHACHA4	151	VINTAGE2	212	VSHUFFLE4
030	JAZZ3	091	CHACHA5	152	FOLKPOP	213	VBLUES1
031	JAZZ4	092	CHACHA6	153	NEWAGE	214	VBLUES2
032	JAZZ5	093	BOSSANOVA1	154	POPBOSSA1	215	VBLUES3
033	JAZZBALLAD	094	BOSSANOVA2	155	POPBOSSA2	216	VBLUES4
034	JAZZWALTZ	095	BOSSANOVA3	156	POPRAP	217	VTWIST1
035	JAZZBAND1	096	SAMBA1	157	POPSAMBA	218	VTWIST2
036	JAZZBAND2	097	SAMBA2	158	8BEAT1	219	VTWIST3
037	JAZZBAND3	098	SAMBA3	159	8BEAT2	220	VTWIST4
038	SWINGJAZZ	099	MAMBO1	160	8BEAT3	221	VGOSPEL1
039	COOLJAZZ	100	MAMBO2	161	8BEAT4	222	VGOSPEL2
040	DIXIELAND1	101	MAMBO3	162	8BEAT5	223	VGOSPEL3
041	DIXIELAND2	102	REGGAE1	163	8BEAT6	224	VR&B
042	FUSION	103	REGGAE2	164	8BEAT7	225	VSWING1
043	LANGE	104	SALSA1	165	8BEAT8	226	VSWING2
044	SOUL1	105	SALSA2	166	8BEAT9	227	VBLUEBOOGIE
045	SOUL2	106	MODERN1	167	8BEATROCK1	228	VJAZZ1
046	SOUL3	107	MODERN2	168	8BEATROCK2	229	VJAZZ2
047	FOXTROT1	108	DANCE1	169	Rock1	230	VJAZZ3
048	FOXTROT2	109	DANCE2	170	Rock2	231	VJAZZ4
049	FOXTROT3	110	DANCE3	171	Rock3	232	VJAZZ5
050	FOXTROT4	111	DANCE4	172	Rock4	233	VJAZZBALLAD
051	FOXTROT5	112	DANCE5	173	Rock5	234	VJAZZWALTZ
052	FOXTROT6	113	DANCE6	174	INDIEROCK1	235	VJAZZBAND1
053	FOXTROT7	114	DANCE7	175	INDIEROCK2	236	VJAZZBAND2
054	FOXTROT8	115	70DISCO1	176	60thRock	237	VJAZZBAND3
055	FOXTROT9	116	70DISCO2	177	GlamMetal1	238	VSWINGJAZZ
056	COUNTRY1	117	DISCO1	178	GlamMetal2	239	VCOOLJAZZ
057	COUNTRY2	118	DISCO2	179	GlamMetal3	240	VDIXIELAND1
058	COUNTRY3	119	DISCO3	180	PunkRock1	241	VDIXIELAND2
059	COUNTRY4	120	VAPERWAVE	181	PunkRock2	242	VFUSION
060	COUNTRY5	121	FUNK1	182	PunkRock3	243	VLANGE
061	COUNTRY6	122	FUNK2	183	PunkRock4	244	VSOU1



Appendix III

Rhythm	LCD	Rhythm	LCD	Rhythm	LCD
245	VSOUL2	306	VMODERN1	367	V8BEATROCK1
246	VSOUL3	307	VMODERN2	368	V8BEATROCK2
247	VFOXTROT1	308	VDANCE1	369	VRock1
248	VFOXTROT2	309	VDANCE2	370	VRock2
249	VFOXTROT3	310	VDANCE3	371	VRock3
250	VFOXTROT4	311	VDANCE4	372	VRock4
251	VFOXTROT5	312	VDANCE5	373	VRock5
252	VFOXTROT6	313	VDANCE6	374	VINDIEROCK1
253	VFOXTROT7	314	VDANCE7	375	VINDIEROCK2
254	VFOXTROT8	315	V70DISCO1	376	V60thRock
255	VFOXTROT9	316	V70DISCO2	377	VGlamMetal1
256	VCOUNTRY1	317	VDISCO1	378	VGlamMetal2
257	VCOUNTRY2	318	VDISCO2	379	VGlamMetal3
258	VCOUNTRY3	319	VDISCO3	380	VPunkRock1
259	VCOUNTRY4	320	VVAPERWAVE	381	VPunkRock2
260	VCOUNTRY5	321	VFUNK1	382	VPunkRock3
261	VCOUNTRY6	322	VFUNK2	383	VPunkRock4
262	VCOUNTRY7	323	VFUNK3	384	VPunkRock5
263	VCOUNTRY8	324	VFUNK4	385	VJIVEROCK
264	VCOUNTRY9	325	VFUNK5	386	VROCKSHUFFLE
265	VCOUNTRY10	326	VFUNK6	387	VROCK'N'ROLL1
266	VCOUNTRY11	327	VFUNK7	388	VROCK'N'ROLL2
267	VCOUNTRY12	328	VR&B1	389	VBEGUINE1
268	VCOUNTRY13	329	VR&B2	390	VBEGUINE2
269	VCOUNTRY14	330	VR&B3	391	VCARIBBEAN
270	VCOUNTRY15	331	VR&B4	392	VBOLERO
271	VCOUNTRY16	332	VR&B5	393	VDANGDUT
272	VCOUNTRYPOP	333	VR&B6	394	VCHINA
273	VCOUNTRYSHUFFLE1	334	V16BEAT1	395	VJIANGNAN
274	VCOUNTRYSHUFFLE2	335	V16BEAT2	396	VXIZANG
275	VCOUNTRYSWING	336	V16BEAT3	397	VYUNNAN
276	VLATIN1	337	V16BEAT4	398	VHAWAII
277	VLATIN2	338	V16BEAT5	399	VGUARACHA
278	VLATIN3	339	V16BEAT6	400	VCHARLESTON
279	VLATIN4	340	V16BEAT7		
280	VLATIN5	341	V16BEAT8		
281	VLATIN6	342	VPOP1		
282	VTANGO1	343	VPOP2		
283	VTANGO2	344	VPOP3		
284	VRUMBA1	345	VPOP4		
285	VRUMBA2	346	VPOP5		
286	VRUMBA3	347	VPOP6		
287	VCHACHA1	348	VPOP7		
288	VCHACHA2	349	VPOP8		
289	VCHACHA3	350	VVINTAGE1		
290	VCHACHA4	351	VVINTAGE2		
291	VCHACHA5	352	VFOLKPOP		
292	VCHACHA6	353	VNEWAGE		
293	VBOSSANOVA1	354	VPOPBOSSA1		
294	VBOSSANOVA2	355	VPOPBOSSA2		
295	VBOSSANOVA3	356	VPOPRAP		
296	VSAMBA1	357	VPOPSAMBA		
297	VSAMBA2	358	V8BEAT1		
298	VSAMBA3	359	V8BEAT2		
299	VMAMBO1	360	V8BEAT3		
300	VMAMBO2	361	V8BEAT4		
301	VMAMBO3	362	V8BEAT5		
302	VREGGAE1	363	V8BEAT6		
303	VREGGAE2	364	V8BEAT7		
304	VSALSA1	365	V8BEAT8		
305	VSALSA2	366	V8BEAT9		



PRODUCT MAINTENANCE

Careful maintenance and protection of this product plays an important role in prolonging the service life of the product and reducing the failure.

1 AVOID HEATING, DAMPNESS OR DIRECT SUNLIGHT

Do not over expose the product to direct sunlight, or place it near air conditioning or extremely hot place.

2 DO NOT USE NEAR THE TV OR RADIO

This product may cause video or audio interference to the reception of TV and radio. If this happens, the product should be removed from the TV or radio.

3 NO DILUENTS OR SIMILAR CHEMICALS SHOULD BE USED FOR CLEANING

Clean the product with a soft cloth wetted with weak water solution and neutral detergent. Soak the cloth in a solution and wring it dry until it approaches drying.

4 DO NOT SHAKE, AVOID COLLISION

When moving, the product should be handled carefully and lightly. Violent vibration and collision are strictly prohibited in order to avoid damage to the shell or internal electronic components.



SAFETY PRECAUTIONS

POWER SUPPLY

This product can be powered by standard indoor wall socket. Please only use the power cord equipped with this product. Be sure to turn off the power when not in use temporarily. When not in use for a long time, please unplug the power cord and keep it properly.

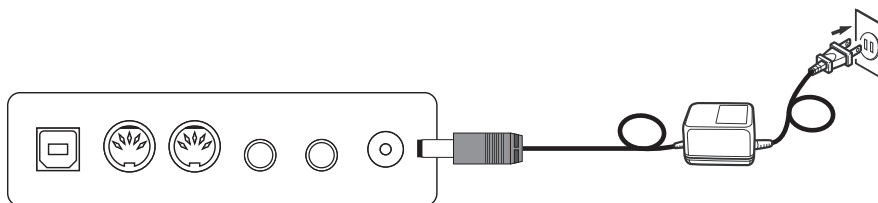

SIGN

To ensure that you use this product safely and correctly, to prevent harm to users and others and financial damage, this manual and products are marked with a series of safety signs. The various signs and their meanings are as follows:

WARNING

This sign indicates that there is a potential risk of death or serious injury if this mark is ignored and the product is mishandled.

BE CAREFUL

This sign indicates that there is a potential danger of injury to personnel or other financial damage if this sign is ignored and the product is operated incorrectly.

EXAMPLE OF LOGO



This triangle sign (\triangle) indicates what users should pay attention to. (The left example is careful shocks)



A circular sign (\odot) with an oblique line indicates prohibitions. The icons in or beside the logo indicate the contents specifically prohibited. (The example on the left is no disassembly)



The round black bottom sign (\bullet) indicates what must be observed. The diagrams in this sign indicate the contents of the specific matters that must be observed. (The example on the left is that the power plug must be pulled out of the socket)



SAFETY PRECAUTIONS

WARNING

Smoke, odor, overheating

When the product smokes, smells or overheats, there is a danger of fire and electric shock when it is used continually. In case of the above situation, the following operations should be performed immediately:

1. Turn off the power supply.
2. Pull the plug out of the power outlet.
3. Contact your dealer.

Power cord

1. The improper use of power cord may cause fire and electric shock. The following precautions must be observed:

- The special power cord designated for this product must be used.
- The AC power supply with output voltage within the rated voltage range for household use must be used.
- Do not overload power sockets and extension lines.



2. The improper treatment of power line will lead to its damage or breakage, which will cause fire and electric shock hazards. The following precautions must be observed:

- Do not place or heat heavy objects on power lines.
- Do not attempt to alter or bend the power cord too much.
- Do not twist or pull the power cord.
- If the power cord or plug is damaged, please replace the same type of power cord.



3. Do not touch the power cord and plug with wet hands, otherwise there is a danger of electric shock.



4. Please use the power cord where the water will not splash. Water is in danger of causing fire and electric shock.



5. Never place vases or any other container containing water on this product. Water is dangerous of causing fire and electric shock.



6. Do not allow minors to unplug and touch power lines or connection boards. Minors have no common sense of electricity safety, which may cause electric shock.



BE CAREFUL

The improper use of power cord may cause fire and electric shock. The following precautions must be observed:

- Never put the power cord near the oven or other heat source.
- Do not pull the cable when pulling out of the power socket. The main body of the plug must be grasped.
- The power cord plug must be inserted in the socket to the end.
- Make sure the power supply is off before connecting or disconnecting it.
- When thunderstorms occur or before traveling or other long-term departure, disconnect the power cord from the wall outlet.
- At least once a year, remove the power cord from the wall outlet and clean the dust accumulated around the plug.



Do not burn this product

Do not put this product in the fire, otherwise it will lead to product combustion and explosion of internal electronic components, which will cause fire and personnel injury.



Water and foreign bodies

Water, other liquids and (metal sheets, etc.) entering this product are in danger of causing fire and electric shock. In case of the above situation, the following operations shall be performed immediately:



1. Turn off the power supply.
2. If you are using a power cord for power supply, unplug it from the wall outlet.
3. Contact your distributor.

Disassembly and transformation

Do not disassemble or transform the product in any way, otherwise there is a risk of electric shock, scald or other personal injury. All internal inspection, adjustment and maintenance operations should be entrusted to your distributor.





SAFETY PRECAUTIONS

Falling or colliding

If the product falls or is damaged by strong impact, it will be in danger of causing fire and electric shock. In case of the above situation, the following operations shall be performed immediately:

1. Turn off the power supply.
2. If you are using a power cord for power supply, you need to unplug it from the wall outlet.
3. Contact your distributor.



Plastic bag

Do not let anyone put plastic bags for this product on his head or in his mouth. Otherwise, there is a risk of asphyxia. Families with young children should pay special attention to it.



Keep a distance from the product and the bracket

Climbing the bracket is dangerous of overturning or damage. Families with young children should pay special attention to it.



Plan

Avoid placing the product on an uneven surface or any other unstable place. Otherwise, it will cause the product to fall down, which will lead to the risk of injury.



Product Mobility

Before moving this product, you must unplug the power cord plug from the wall outlet and pull out all other cables and connecting wires. Otherwise, it will lead to damage of power or connection wires, resulting in fire and electric shock.



Clean

Before cleaning this product, you must unplug the power cord plug from the wall outlet, otherwise there is a risk of fire and electric shock.



Jack

The socket of this product can only be connected to the designated equipment and devices. Connecting non-designated equipment or devices is dangerous of causing fire and electric shock.



Location selection

It should be avoided to place the product in the following places, otherwise there is a risk of fire and electric shock.



- High temperature or dusty places.
- Kitchen or other places with lampblack.
- Where the product is exposed to direct sunlight, or any other place where the product will produce high temperature.

Volume

Don't play music long and loud. Pay special attention when using headphones. Excessive volume can damage your hearing.



Heavy

Do not place heavy objects on this product. Otherwise, the top of the product will be overweight, causing the product to overturn or drop objects on it, which will lead to the risk of injury.



Correct assembly of scaffolds

The incorrect assembly of the bracket may overturn, causing the product to fall off and posing a risk of injury to personnel. Therefore, it must be assembled according to the instructions in the attached installation guide to ensure that the product is properly mounted on its bracket.





WARRANTY CARD

Warranty Rules

1. Faults arising from normal use of this product can be guaranteed free of charge for 1 year from the date of purchase.
2. Failure occurs during the warranty period. This warranty card and shopping ticket must be presented during maintenance.
3. In the following cases, no free warranty will be provided:
 - Damage caused by improper use by users.
 - Fault damage caused by irresistible factors such as fire, flood, earthquake and lightning strike.
 - Failure caused by unauthorized self-disassembly.
4. After exceeding the warranty period, the company is responsible for maintenance, but it needs to charge a cost fee.

Seller: _____

Address: _____

Telephone: _____

Maintenance record

Date	Maintenance record	Repairman

